

3.10 GEOGRAPHY (312)

3.10.1 Geography Paper 1 (312/1)

SECTION A

Answer all the questions in this section.

- 1** The diagram below represents the structure of the earth. Use it to answer question (a).

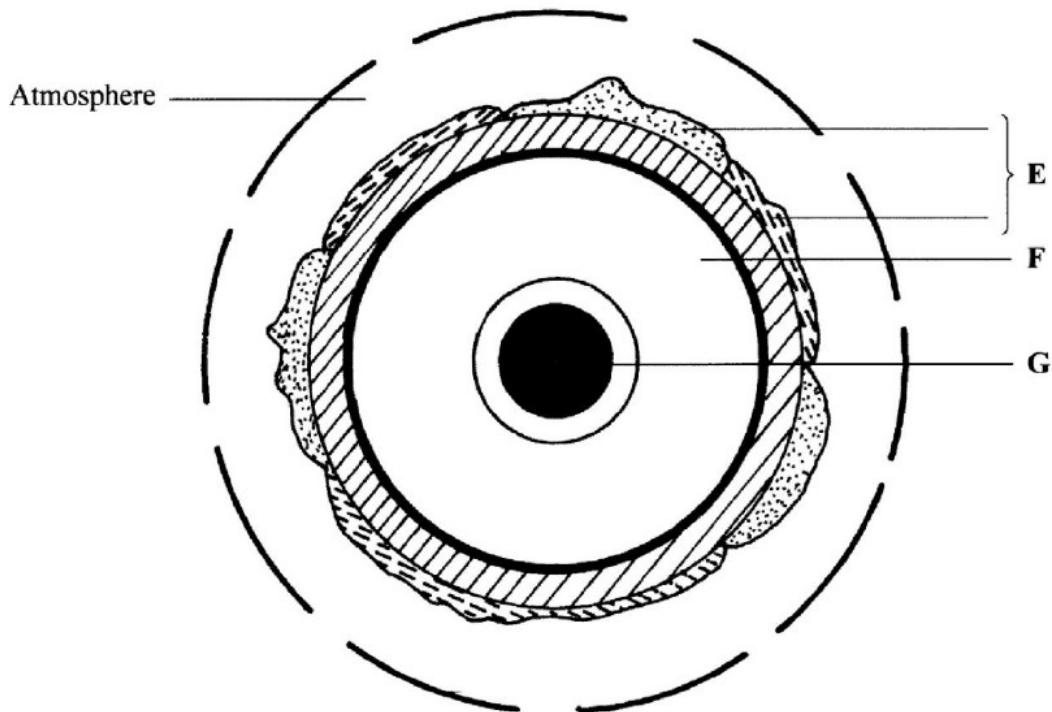

- (a) Name:
- (i) the layers marked **E** and **F**. (2 marks)
 - (ii) the minerals that make up the layer marked **G**. (2 marks)
- (b) Give **two** effects of the rotation of the earth on its axis. (2 marks)
- 2**
- (a) What is a metamorphic rock? (2 marks)
 - (b) Give **three** examples of metamorphic rocks. (3 marks)
- 3**
- (a) Name **two** types of boundaries according to the plate tectonic theory. (2 marks)
 - (b) Give **three** effects of the movement of tectonic plates. (3 marks)

- 4 (a) What is an earthquake? (2 marks)
- (b) Identify the scale used to measure:
- (i) the intensity of earthquakes; (1 mark)
- (ii) the magnitude of earthquakes. (1 mark)
- 5 (a) Give **three** characteristics of a river in its middle stage. (3 marks)

The diagram below shows a Bird's foot delta. Use it to answer question (b).

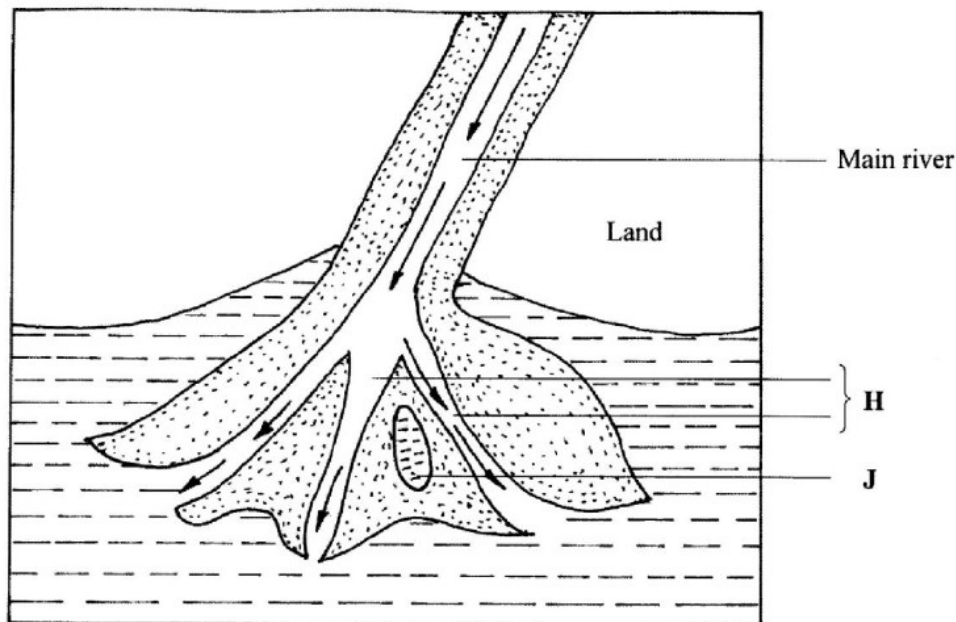

- (b) Identify the features marked **H** and **J**. (2 marks)

SECTION B

Answer **question 6** and any other **two** questions from this section.

- 6 Study the map of Busia 1:50,000 (sheet 101/1) provided and answer the following questions.
- (a) (i) Convert the ratio scale of the map extract into a statement scale. (2 marks)
- (ii) What is the general direction of flow of river Sio? (1 mark)
- (iii) Identify the **two** dominant types of natural vegetation shown in the area covered by the map. (2 marks)
- (b) Draw a square 10 cm by 10 cm to represent the area to the west of Easting 30 and north of Northing 40. On the square, mark and label:
- (i) an international boundary;
- (ii) an air photo principal point;

- (iii) river Sio;
 - (iv) the area above 1200 metres above sea level. (5 marks)
- (c) Describe the relief of the area covered by the map. (5 marks)
- (d) (i) Explain how the following factors have influenced the distribution of settlements in the area covered by the map:
- drainage; (2 marks)
 - transport. (2 marks)
- (ii) Citing evidence from the map, state **three** functions of Funyula town. (6 marks)
- 7 (a) (i) Define the term weather. (2 marks)
- (ii) Explain how the following factors influence weather:
- cloud cover; (4 marks)
 - local winds. (4 marks)

The diagram below represents a weather measuring instrument. Use it to answer question (b).

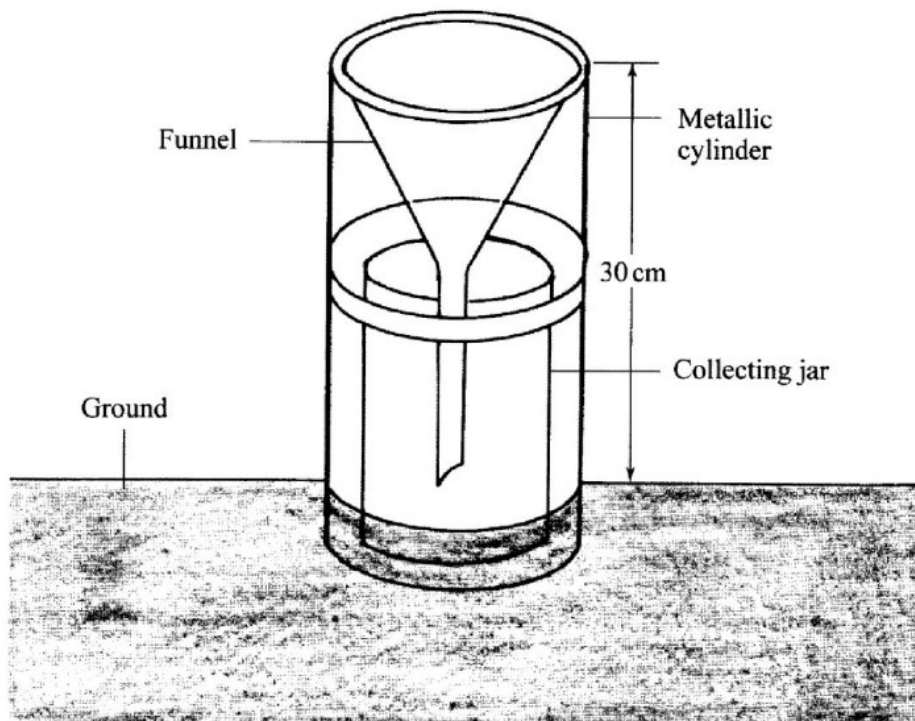

- (b) (i) Which element of weather is measured using the instrument shown above? (1 mark)
- (ii) Describe how the above instrument is used. (3 marks)

The table below shows the temperature and rainfall readings for station **T** in one week. Use it to answer question (c).

Day	Mon	Tue	Wed	Thu	Fri	Sat	Sun
Temperature °C	23	23	24	21	25	25	23
Rainfall in mm	50	49	55	45	60	60	49

- (c) (i) Calculate:
- the range of temperature for the week. (1 mark)
 - the mean weekly rainfall. (2 marks)
- (ii) State **four** characteristics of the weather in station **T**. (4 marks)
- (d) Give **four** characteristics of the stratosphere. (4 marks)
- 8** (a) (i) Apart from the Rift Valley, name **three** other relief features formed as a result of faulting. (3 marks)
- (ii) With the aid of diagrams, describe how the Great Rift Valley may have been formed by tensional forces. (8 marks)
- (b) Explain **three** ways in which faulting may influence drainage systems. (6 marks)
- (c) Describe **four** ways in which features resulting from faulting are of significance to the economy of Kenya. (8 marks)
- 9** (a) (i) Apart from alternate wetting and drying, name **three** other processes of mechanical weathering. (3 marks)
- (ii) Describe the following processes of weathering:
- alternate wetting and drying; (3 marks)
 - hydrolysis; (2 marks)
 - carbonation. (3 marks)
- (b) (i) State **three** conditions that influence the process of solifluction in mass wasting. (3 marks)
- (ii) Give **three** negative effects of mass wasting on the physical environment. (3 marks)
- (c) You are planning to carry out a field study on types of mass wasting.
- (i) Identify **three** methods you would use to collect data. (3 marks)
- (ii) Give **three** types of rapid mass wasting that you are likely to observe during the field study. (3 marks)

- (iii) State **two** ways in which the information collected during the field study would be useful to the local community. (2 marks)

10 The diagram below represents an artesian basin. Use it to answer question (a).

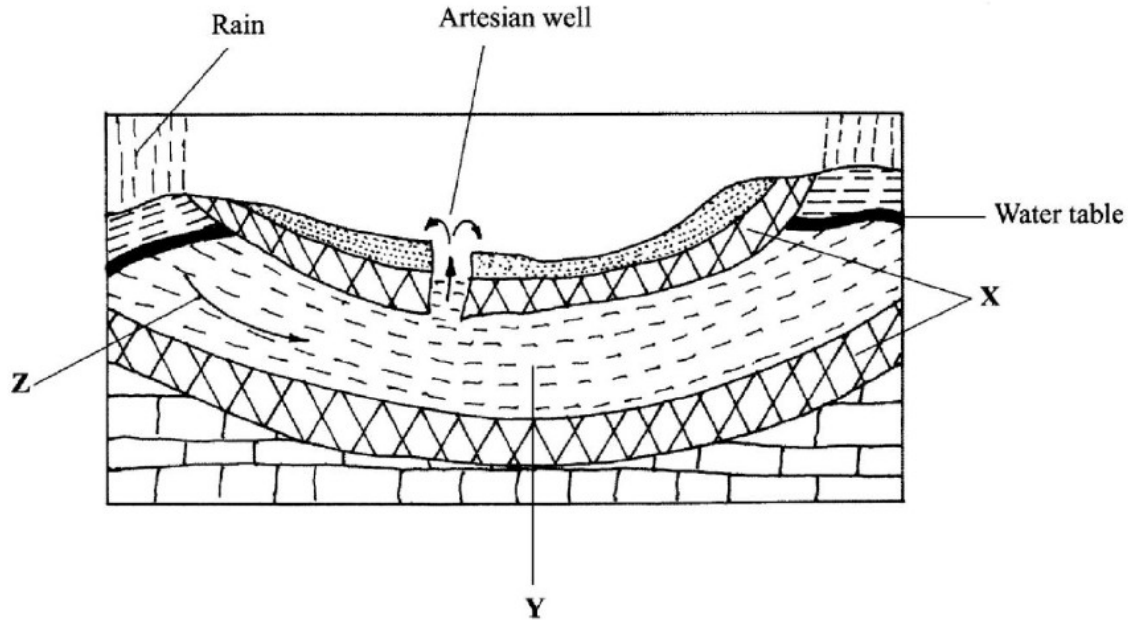

- (a) Identify:
- (i) the layers marked X and Y. (2 marks)
 - (ii) the process marked Z. (1 mark)
- (b) Explain how the following factors influence the amount of underground water in limestone areas:
- (i) rainfall; (4 marks)
 - (ii) vegetation cover. (4 marks)
- (c) (i) Apart from stalagmites, name **three** other underground features formed in limestone areas. (3 marks)
- (ii) With the aid of a diagram, describe how a stalagmite is formed. (8 marks)
- (d) Give **three** reasons why there are few settlements in Karst landscapes. (3 marks)

3.10.2 Geography Paper 2 (312/2)

SECTION A: (25 marks)

Answer *all* the questions in this section.

- 1 (a) Define the term environment. (2 marks)
- (b) Give **three** effects of air pollution in major urban centres. (3 marks)
- 2 (a) Identify **three** factors that influence the occurrence of minerals. (3 marks)
- (b) Name the area where the following minerals are mined in Kenya:
- (i) diatomite; (1 mark)
- (ii) salt. (1 mark)
- 3 (a) Distinguish between forest and forestry. (2 marks)
- (b) Identify **three** activities that may be undertaken in your school to conserve trees. (3 marks)
- 4 Give **four** challenges facing Nomadic pastoralism in Kenya. (4 marks)
- 5 Use the map of Kenya below to answer question (a).

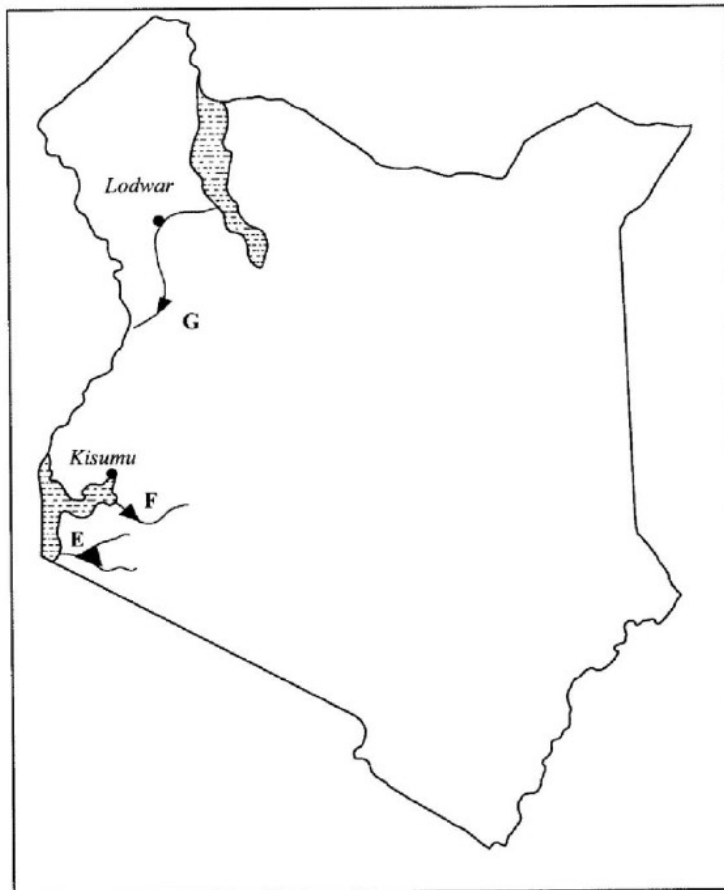

- (a) Name the hydro-electric power projects marked E, F and G. (3 marks)
- (b) State **three** advantages of geothermal power as a source of energy. (3 marks)

SECTION B: (75 marks)

Answer question 6 and any other two questions in this section.

- 6 The table below shows the value of some of Kenya's mineral exports from 2008 to 2011. Use it to answer questions (a) and (b).

Value of Kenya's mineral exports (Million Ksh.)

Mineral \ Year	2008	2009	2010	2011
Soda Ash	13 200	8 300	7 300	12 400
Petroleum Products	4 200	4 500	4 700	6 100
Cement	7 300	7 800	7 400	8 900

Source: Central Bureau of Statistics

- (a) (i) Using a scale of 1 cm to represent 1 000 million Kenya Shillings, draw a comparative bar graph to represent the data shown. (8 marks)
- (ii) State **three** advantages of using comparative bar graphs to represent statistical data. (3 marks)
- (b) Calculate the percentage increase in value of exports between the years 2010 and 2011. (6 marks)
- (c) Explain the significance of trade to the economy of Kenya. (8 marks)
- 7 (a) State **three** physical conditions which favour large scale sugarcane growing in Kenya. (3 marks)
- (b) (i) Describe the stages involved in the processing of sugarcane at the factory. (6 marks)
- (ii) Give **three** by-products obtained from sugarcane. (3 marks)
- (c) Explain **three** ways in which the Kenya Government is promoting the sugar manufacturing industry. (6 marks)
- (d) Your class visited a sugarcane plantation for a field study on land preparation and planting.
- (i) Outline **four** activities that you are likely to identify. (4 marks)
- (ii) Give **three** methods you would use to record data during the field study. (3 marks)

- 8 (a) Differentiate between domestic and international tourism. (2 marks)

Use the map of East Africa below to answer question (b).

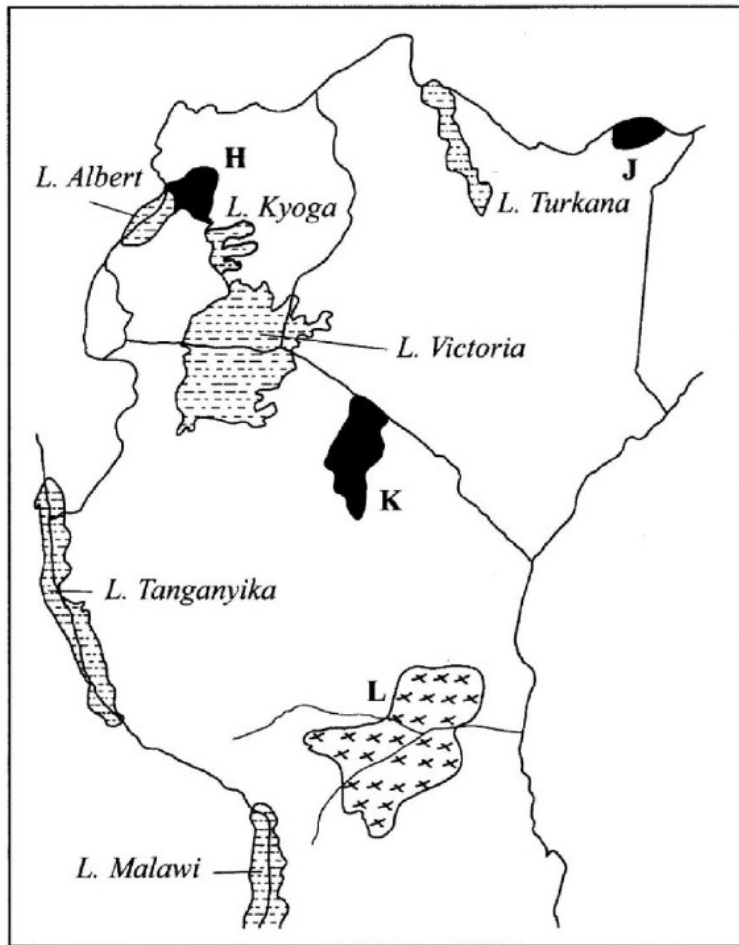

- (b) Name:
- (i) The national parks marked **H**, **J** and **K**. (3 marks)
 - (ii) The game reserve marked **L**. (1 mark)
- (c) (i) Explain how the following factors influence tourism in Kenya. (2 marks)
- climate; (2 marks)
 - scenery; (2 marks)
 - tour companies. (2 marks)
- (ii) State **five** effects of floods on tourism. (5 marks)
- (d) Explain **four** ways in which the county governments in Kenya would promote sustainable tourism. (8 marks)

9 Use the map of Africa below to answer question (a)

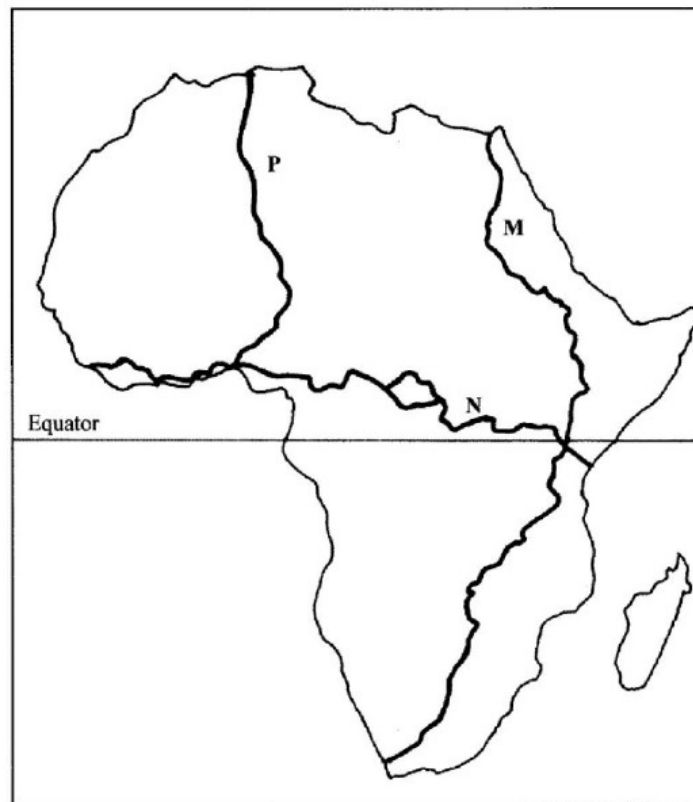

- (a) Name the trans-continental highways in Africa marked M, N and P. (3 marks)
- (b) (i) State **four** advantages of air transport. (4 marks)
- (ii) Explain **four** efforts that the Kenya Government has taken to improve air transport. (8 marks)
- (c) (i) Identify **two** types of communication. (2 marks)
- (ii) Explain **four** problems facing communication in Africa. (8 marks)
- 10 (a) (i) Give **two** main sources of population data. (2 marks)
- (ii) Outline the information that can be derived from a population pyramid. (3 marks)
- (b) Explain how the following factors have led to population increase in Kenya
- (i) cultural beliefs; (2 marks)
- (ii) migration. (2 marks)
- (c) Explain **four** problems which result from a high population growth rate in Kenya. (8 marks)
- (d) Describe **four** ways in which the population of Kenya differs from that of Sweden. (8 marks)