

3.22 AVIATION TECHNOLOGY (450)

3.22.1 Aviation Technology Paper 1 (450/1)

SECTION A (44 marks)

Answer all questions in this section.

- 1 (a) List **four** causes of electric shock as laid down in safety practices. (2 marks)
- (b) State **one** reason for bonding an aircraft during refuelling. (1 mark)
- 2 (a) Differentiate between the following terms as applied to materials:
- (i) Mechanical properties; (1 mark)
- (ii) Chemical properties. (1 mark)
- (b) Sketch each of the following aircraft hardware and state where each is applied:
- (i) Spring washer; (1 mark)
- (ii) Woodruff key; (1 mark)
- (iii) Countersunk rivet. (1 mark)
- 3 (a) Outline **two** environmental issues associated with the aviation industry. (2 marks)
- (b) Name **two** types of clouds with vertical development. (1 mark)
- 4 (a) List **three** challenges likely to affect the performance of a well managed international airline. (3 marks)
- (b) State the functions of each of the following in a Non-Destructive testing process:
- (i) Penetrants; (1 mark)
- (ii) Developers. (1 mark)
- 5 State the methods used to join each of the following aircraft parts:
- (a) Honey-comb structures; (1 mark)
- (b) Engine fire wall. (1 mark)
- 6 Explain the principle of generating thrust in each of the following aircraft engines:
- (a) reciprocating engine; (2 $\frac{1}{2}$ marks)

(b) pure jet engine. (2½ marks)

7 Name **five** stresses acting on an aircraft in flight and state where each is applicable. (5 marks)

Types of stress	Where applicable
.....

8 (a) Outline **four** functions of an aircraft undercarriage. (4 marks)

(b) State **three** basic principles of air navigation. (3 marks)

9 Outline **five** methods of reducing skin-friction associated with the boundary layer in flight. (5 marks)

10 Sketch and show the abbreviation of the following as applied in engineering drawing:

(a) across flats; (1 mark)

(b) under cut; (1 mark)

(c) counterbore; (1 mark)

(d) centreline. (1 mark)

SECTION B (56 marks)

*Answer any **four** questions from this section.*

11 (a) List **four** causes of 75% of air accidents caused by human error in the aviation industry. (2 marks)

(b) Explain **three** business opportunities for chartered aircraft operators. (6 marks).

(c) Explain the role of each of the following in the Aviation Industry:

(i) marshaller; (1½ marks)

(ii) flight Engineer; (1½ marks)

(iii) air traffic controller; (1½ marks)

(iv) Purser. (1½ marks)

- 12 (a) Outline **four** methods used to vary the flow of fuel in an aircraft engine. (4 marks)
- (b) Explain the principle of operation of an aero piston engine float type carburetor. (4 marks)
- (c) Explain the principle of operation of each of the following aircraft gas turbine engine burners:
- (i) simplex burner; (3 marks)
- (ii) duplex burner. (3 marks)
- 13 (a) Explain the meaning of **four** colour markings on aircraft instruments. (4 marks)
- (b) Define the term graticule as applied in navigation. (1 mark)
- (c) Aircraft A is flown from point X, $26^{\circ} 30' N$ to point Y, $44^{\circ} 30' N$ while aircraft B is flown from point Q $170^{\circ} E$ to point P, $165^{\circ} W$. Determine the change in latitude and longitude respectively for aircrafts A and B in degrees and minutes. (9 marks)

14 **Figure 1** shows an aircraft hinge bracket, drawn in isometric projection.

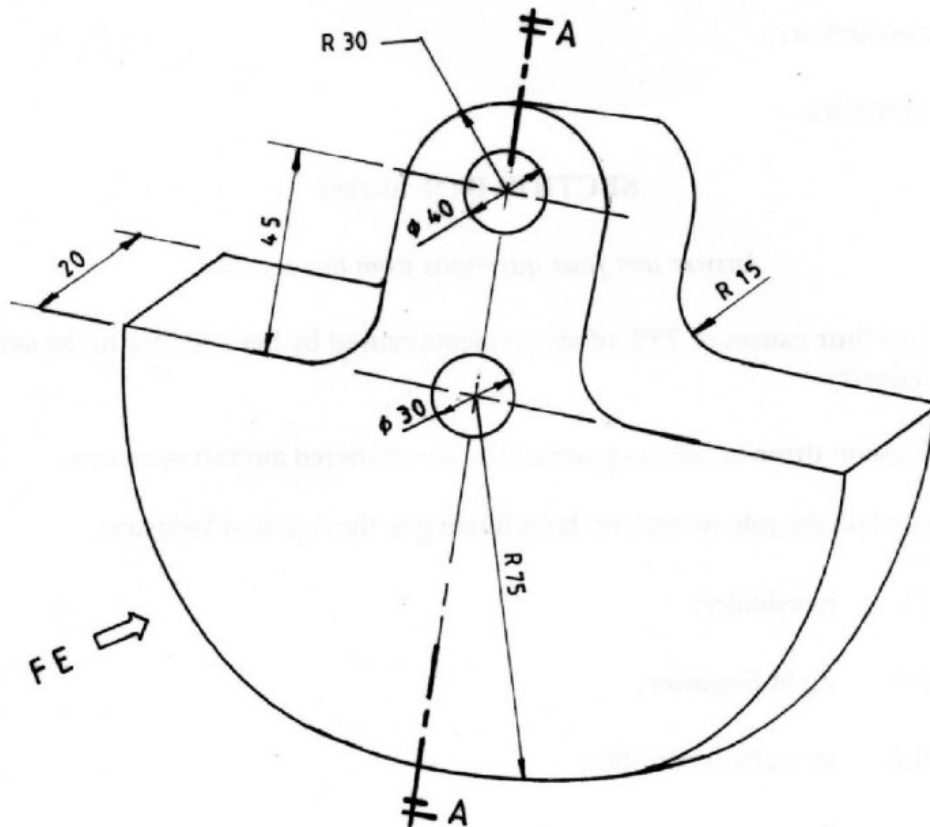

Draw FULL SIZE in first angle projection the following views:

- (a) front elevation in the direction of arrow F.E.
 - (b) Section A-A.
 - (c) Plan
- (Use the A3 paper provided)** (14 marks)

- 15** (a) Describe each of the following aircraft structural members:
- (i) bulk head; (2 marks)
 - (ii) longerons; (2 marks)
 - (iii) spars. (2 marks)
- (b) **Figure 2** shows a basic hydraulic system. Identify the components labelled 1 to 6. (3 marks)

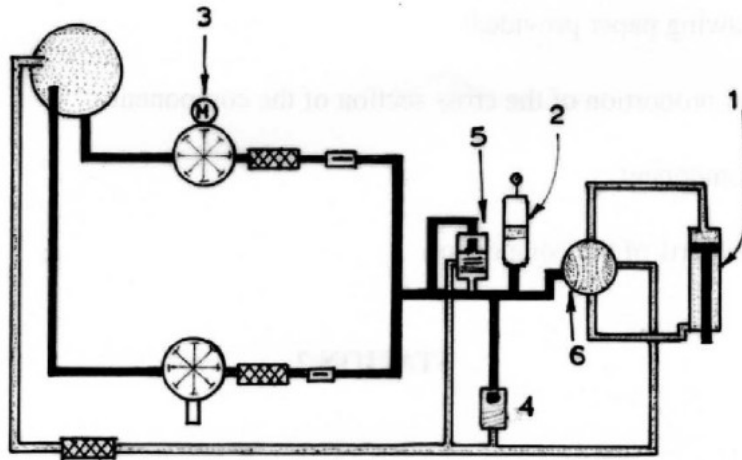

Figure 2

- 1.
- 2.
- 3.
- 4.
- 5.
- 6.

- (c) Outline **five** reasons why a thread cutting tap may break while in use. (5 marks)

3.22.2 Aviation Technology Paper 2 (450/2)

STATION 1

INSTRUCTIONS

Figure 1 shows a pictorial drawing of a hydraulic system component.

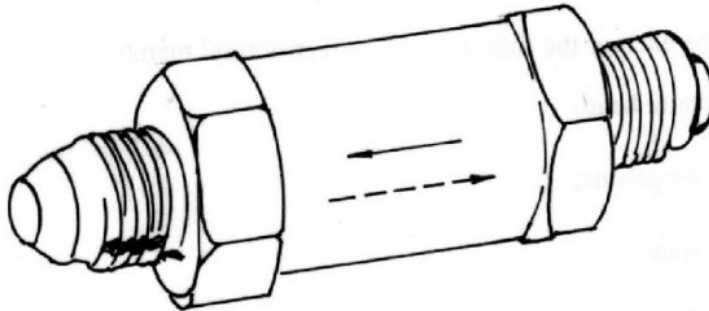

Figure 1

On the A3, drawing paper provided:

- (a) Sketch in good proportion of the cross section of the component.
- (b) Identify the component.
- (c) Label **six** main parts of the component. (10 marks)

STATION 2

INSTRUCTIONS

Using the template, tools, and materials provided, make the aircraft ram air scoop shown in figure 2. (10 marks)

STATION 3

INSTRUCTIONS

Using the tools and materials provided, carry out the following tasks:

- (a)
 - (i) Scribe each of the materials labeled A, B and C. Record your observations. (1 $\frac{1}{2}$ marks)
 - (ii) Centre punch each material in a(i). Record your observations. (1 $\frac{1}{2}$ marks)
 - (iii) File each of the materials in a(i). Record your observations. (1 $\frac{1}{2}$ marks)

- (iv) Bend each of the materials in a(i) to 90°. Record your observations. (1 $\frac{1}{2}$ marks)
- (b) From the observations (i) - (iv), comment on the hardness of each material. (1 $\frac{1}{2}$ marks)
- (c) Identify the materials labelled A and C. (1 mark)
- (d) State where each of the materials in a(i) can be used on an aircraft. (1 $\frac{1}{2}$ marks)

SECTION 4

INSTRUCTIONS

- (a) Figure 3 shows a sectional view of an aircraft pulley provided.

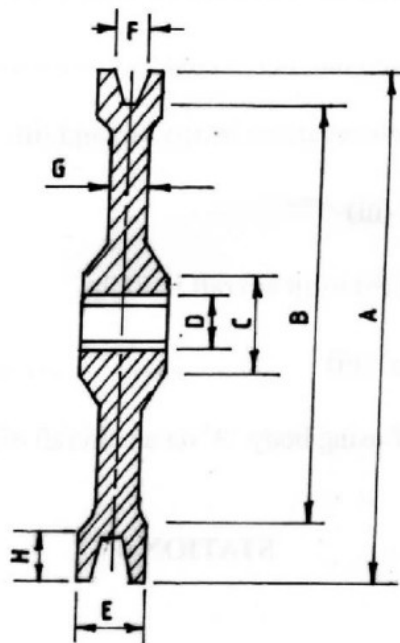

- Using the tools, measure and record the dimensions A- H as shown in the figure. (8 marks)
- (b) Identify the function of the part painted red on the pulley. ($\frac{1}{2}$ mark)
- (c) State **two** rejection criteria and **one** maintenance aspect of the pulley.
 - (i) Rejection criteria (1 mark)
 - (ii) Maintenance aspect ($\frac{1}{2}$ mark)

STATION 5

INSTRUCTIONS

Study the set up provided and perform the following tasks:

- (a) (i) Pour 300 ml of water at point A. Record the amount collected in beaker A1.
Amount of water
- (ii) Repeat a(i) at B. Record the amount of water collected in beaker B1.
Amount of water
- (iii) Repeat a(i) at C. Record the amount of water collected in beaker C1.
Amount of water (6 marks)
- (b) State the reasons for your observations in a(i), (ii) and (iii)
Observation in (i), (ii) and (iii) (1½ marks)
- (c) Relate your observation in (b) to an aircraft in flight.
Relationship in b(i), (ii) and (iii) (1½ marks)
- (d) State **two** overall effects of using body 'A' on an aircraft effects (1 mark)

STATION 6

INSTRUCTIONS

Using the tools and materials provided, carry out the following tasks.

- (a) Identify the materials labelled 'X' and 'Y' (1 mark)
- (b) Strip one end of material labelled 'X' and name the parts. (2 marks)
- (c) (i) Tin the stripped end of material labelled 'X'.
(ii) Clip the male and female connectors on the material labelled 'Y'. (7 marks)

STATION 7

INSTRUCTIONS

Using the tools, wheel assembly and brake assembly provided, carry out the following

- (a) On the whole assembly
- (i) Check the tyre pressure.
Pressure (1 mark)
- (ii) Torque load the nut painted red to 60 450 lbs . Let the examiner check your work. (1 mark)
- (iii) Identify the tyre size and ply rating.
Size
Ply rating (1 mark)
- (iv) Identify and record **two** rejection criteria.
Criteria (i) (1 mark)
- (v) State the purpose of the blue and white marks.
Blue
White (1 mark)
- (b) Safely wire the bolts on the brake assembly. (5 marks)

STATION 8

INSTRUCTIONS

Using the tools and the engine components provided, carry out the following tasks:

- (a) (i) Identify the components labelled M and N.
(ii) Measure and record the gap of the component labelled N.
Gap (2 marks)
- (b) (i) Remove the cap on the component M.
Let the examiner check your work.

(ii) Identify the parts painted white and yellow.

White

Yellow

(iii) State the condition of distribution points.

(iv) Replace the cap.

Let the examiner check your work.

(4 marks)

(c) (i) Fit the leads on the component marked M to match the best firing order.

Let the examiner check your work.

(ii) State **two** rejection criteria of the part labelled P.

(iii) State **two** functions of the part painted blue on component M.

(4 marks)

STATION 9

INSTRUCTIONS

Study aircraft instruments marked 1 to 9 and carry out the following tasks.

(6 marks)

(a) Group the instruments into three major categories and complete the table below.

GROUP NAME	RELATED INSTRUMENTS
1.	(i) (ii) (iii)
2.	(i) (ii) (iii)
3.	(i) (ii) (iii)

(b) State the reasons for each grouping in (a).

GROUP REASON

(1½ marks)

(c) Name **three** settings made on instrument labelled 10. (1 $\frac{1}{2}$ marks)

(d) Name **one** common error and maintenance task for instruments labelled 1 to 9. (1 mark)

Error

Maintenance task

STATION 10

INSTRUCTIONS

(a) Demonstrate to the examiner six marshalling signals from starting to taxiing out on a twinned engine aircraft. (3 marks)

(b) Identify and state the use of areas labelled A, B, C, D and E. (5 marks)

AREA NAME	USE
-----------	-----

(c) (i) State the name of runway and the direction of take off/landing.

Runway

Direction

(ii) Give the functions of G and H. (2 marks)

G

H