

NAME: ADM NO.....

SCHOOL: DATE.....

SIGNATURE:

121/2

MATHEMATICS

PAPER 2

2¹/₂ HOURS

(KENYA CERTIFICATE OF SECONDARY EDUCATION)

INSTRUCTIONS TO CANDIDATES:

- Write your name and admission number in the spaces provided above
- This paper contains two sections; Section I and section II.
- Answer all the questions in section I and only five questions from section II.
- All workings and answers must be written on the question paper in the spaces provided below each question.
- Marks may be given for correct working even if the answer is wrong.
- Calculators and KNEC mathematical tables may be used EXCEPT where stated otherwise
- Show all the steps in your calculations, giving your answers at each stage in the spaces below each question

For Examiner's Use Only;

Section I

Questions	1	2	3	4	5	6	7	8	9	10	11	12	13	14	15	16	TOTAL
Marks																	

Section II

Questions	17	18	19	20	21	22	23	24	TOTAL
Marks									

GRAND

--

NB.12 Pages are printed

1. Evaluate without using tables or calculators. (3mks)

$$\sqrt{\frac{0.8064 \times 6.048}{1.008 \times 0.1344}}$$
2. Evaluate $\frac{-4 \text{ of } [(-4 + -5 \div 15) + -3 - 4 \div 6]}{84 \div -7 + 3 - -5}$ (2mks)
3. Solve for θ without using table given that $0 \leq \theta \leq 90^\circ$ and that $\sin (2\theta - 30^\circ) - \cos 4\theta = 0$ (3mks)
4. Solve for x given that $5^{2x+2} - 20 \times 5^{2x} = 625$ (3mks)
5. The angle of a quadrilateral ABCD in order are $2(x - 10)$, $4(x + 5)$, $5(x + 4)$ and $(x - 20)$ in degrees. Find the exterior angles of the quadrilateral. (4mks)
6. A radio costing kshs. 1240 is marked to sell at a price calculated to give a profit of 40 %. What will be its selling price in sale when 25% is taken off the marked price? (3mks)
7. Show that if $OA = -i + 7j$, $OB = 3i - 5j$ and $OC = 4j$, then points A, B and C are collinear. (4mks)

8. Four men can dig 2 acres of land in 3 days working 4 hour a day. How many men are required to dig 5 acres of land in 4 days working 3 hours a day at the same rate. (3mks)

9. The surface area of two similar bottles are 12 cm^2 and 108 cm^2 respectively. If the larger one has a volume of 810 cm^3 . Find the volume of the smaller one. (3mks)

10. In the figure given below, AC is an arc of a circle centre B $\angle ABD = 60^\circ$, $AB = BC = 7 \text{ cm}$ and $CD = 5 \text{ cm}$.

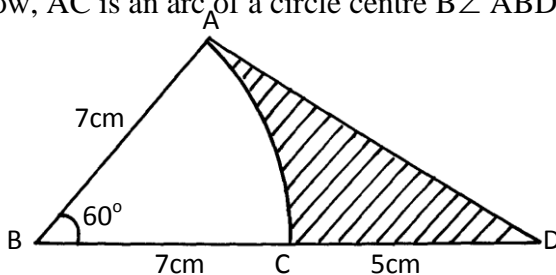

Calculate

- a) The area of triangle ADB (2mks)

- b) The area of the shaded region. (2mks)

11. Solve the inequalities and represent the information on the number line. (3mks)
 $-3 + 2x < 3x + 2 < 4(x - 5)$

12. Make x the subject of the formula in $3s = 2p\sqrt{\frac{x}{3x - 5}}$ (3mks)

13. Given $x = 13.4 \text{ cm}$ and $y = 4.3 \text{ cm}$. calculate the percentage error in $\frac{x}{y}$ correct to 4 d.p (3mks)

14. A straight line through the point A (2, 1) and B (4,m) is perpendicular to the line whose equation is $3y = 5 - 2x$, Determine the value of m. (3mks)
15. Okoth deposited some money at 10% compound interest compounded annually. How long will it take to double the amount to the nearest year? (3mks)
16. Chebet has 5 brown chicken and 3 black ones. She picks two of them for slaughter at random, one after the other. What is the probability that the two are of different colours. (3mks)

SECTION II

Answer only five questions.

17. A bus left Nairobi at 8.00am and traveled towards Busia at an average speed of 80km/hr. At 8.30 am a car left Busia for Nairobi at an average speed of 120km/hr. Given that the distance between Nairobi and Busia is 400km.

Calculate:

- a) The time the car arrived in Nairobi. (2mks)
- b) The time the two vehicles met. (4mks)
- c) The distance from Nairobi to the meeting point. (2mks)
- d) The distance of the bus from Busia when the car arrived in Nairobi. (2mks)

18. A triangle whose vertices are A (1,4) B (2,1) and C (5,2) is given the following transformation:

- i) Reflection in the line $y = -x$ to $A^1B^1C^1$
- ii) $A^1B^1C^1$ is then given rotation of $+ 90^\circ$ about the origin to $A^{11}B^{11}C^{11}$
- iii) $A^{11}B^{11}C^{11}$ is then given a translation vector $\begin{bmatrix} -2 \\ \end{bmatrix}$ to $A^{111}B^{111}C^{111}$
- iv) $A^{111}B^{111}C^{111}$ is then given an enlargement scale factor $- 2$ centre (0, 0) to $A^{IV}B^{IV}C^{IV}$.

On the given grid plot a triangle ABC and it's images $A^1B^1C^1$, $A^{11}B^{11}C^{11}$, $A^{111}B^{111}C^{111}$ and $A^{IV}B^{IV}C^{IV}$.
And give coordinates of $A^{IV}B^{IV}C^{IV}$. (10mks)

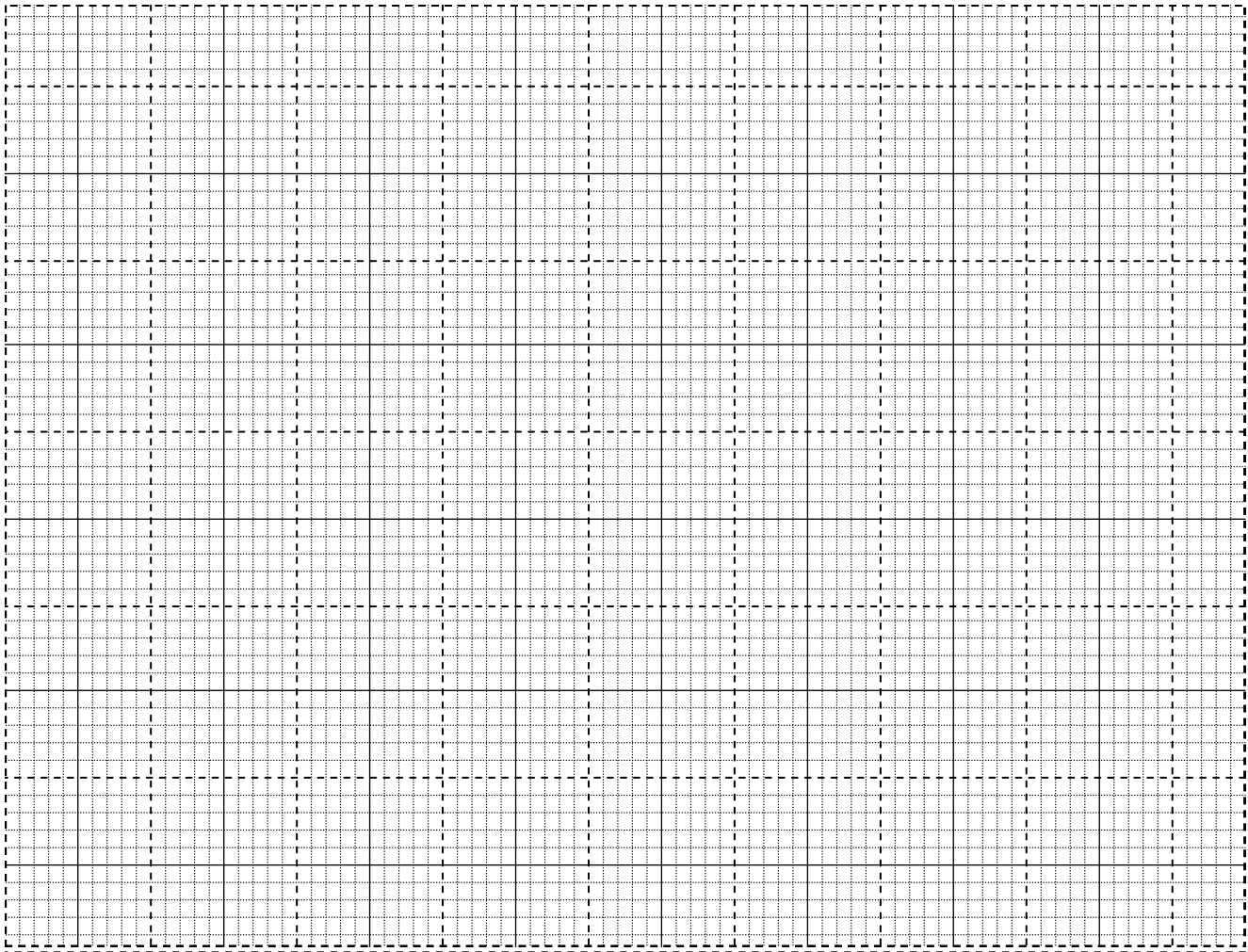

19. A Post OT stand vertically on level ground John moves from O, the foot of the flag post to point R, on the level ground. The points T, O and R form a right angled isosceles triangle whose perimeter is 56m. S is another point on the level ground 35m from O calculate:

- a) The angle of elevation of T from S. (6mks)
- b) The distance ST. (2mks)

c) Find the maximum possible distance between R and S. (2mks)

20. A salesman received a basic salary of sh. 50,000 a year together with a commission of 6 % on the value of goods sold and a car allowance of sh. 2.50 per km.

a) Find the total amount he received in a year in which he sells goods worth sh. 625,000 and travels 10,000km. (4mks)

b) The next year he travels 12,000km and receives a total of shs. 134,000

- i) Calculate the value of goods sold. (4mks)
- ii) Calculate the percentage increase in the value of the goods sold. (2mks)

21. Two airports A and B are such that B is 500km due east of A. Two planes P and Q take off from A and B respectively and at the same time.

Plane P flies at 360km/hr on a bearing of 030°

Plane Q flies at 240km/hr on a bearing of 315°

The two planes land after 90 minutes.

Using a scale of 1: 10,000,000

- a) Show the positions of the planes after 90 min. (6mks)
- b) Find the distance between the planes after 90 min. (2mks)
- c) Find the bearing of plane Q from plane P after 90 minutes (2mks)

22. The figure below shows a container in the form of a frustrum of an open top with a top radius of 40cm and a base radius of 24cm. The depth is 56 cm.

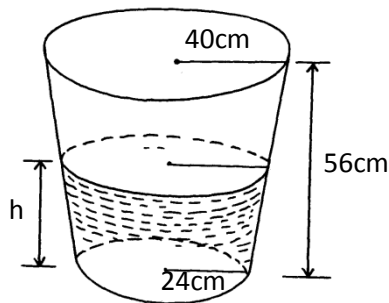

- a) Calculate the volume of the container in litres. (4mks)
- b) If the container is $\frac{3}{4}$ full of water by volume, calculate the radius of the meniscus. (6mks)

23. The table below shows values of x and some values of y for the curve $y = x^3 + 2x^2 - 3x - 4$ For $-3 \leq x \leq 2$

X	-3	-2.5	-2	-1.5	-1	-0.5	0	0.5	1	1.5	2
---	----	------	----	------	----	------	---	-----	---	-----	---

Y	-4.0	-0.4		1.6	0		-4.0	-4.9			6
---	------	------	--	-----	---	--	------	------	--	--	---

Complete the table by filling in the missing values of y , correct to 1 decimal place. (2 marks)

b) On the grid provided, draw the graph of $y = x^3 + 2x^2 - 3x - 4$.

Use the scale: 1 cm represents 0.5 units on x axis. 1 cm represents 1 unit on y axis.

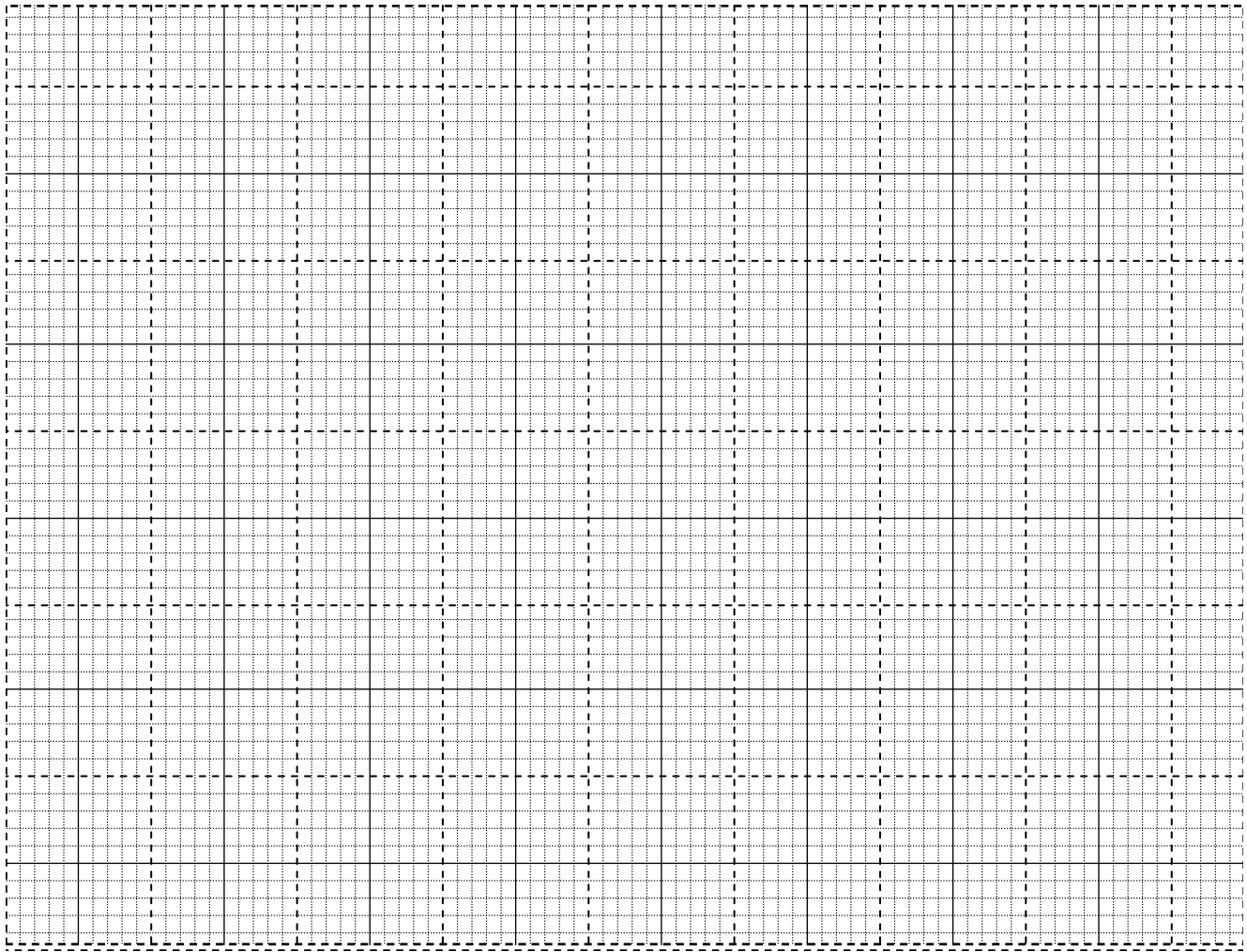

(c) Use the graph to: (3 marks)

(i) Solve the equation $x^3 + 2x^2 - 3x - 4 = 0$; (3 marks)

(ii) Estimate the coordinates of the turning points of the curve. (2 marks)

24. The diagram below shows the graph of a moving matatu from one bus stop to another.

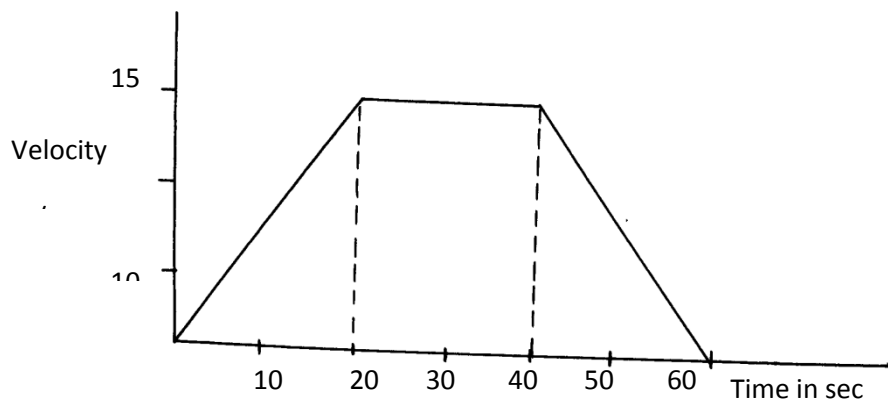

a) Find the acceleration of the matatu. (2mks)

b) Find the deceleration of the matatu (2mks)

c) Calculate the distance the matatu while accelerating. (2mks)

d) Calculate the distance the matatu covered while traveling at an acceleration of 0m/s^2 (2mks)

e) Find the distance between the two bus stops. (2mks)