

NAME.....ADM NO.....

SCHOOL.....STUDENT'S SIGN.....

DATE.....

233/1

CHEMISTRY PAPER 1

FORM 3, 2018

Time: 1 Hour

(KENYA CERTIFICATE OF SECONDARY EDUCATION)

INSTRUCTIONS TO STUDENTS

1. Answer ALL the questions
2. Mathematical tables and electronic calculations may be used
3. All working MUST be clearly shown where necessary

FOR EXAMINER'S USE ONLY:

Questions	Max. score	Candidates score
1 - 11	50	

1. a) Distinguish between ionization energy and electron affinity. (2mks)

.....
.....
.....

b) The atomic number of A and B are 9 and 17 respectively. Compare the electron affinity of A and B. Explain. (1mk)

.....
.....

2. Use the reaction scheme below to answer the questions that follow.

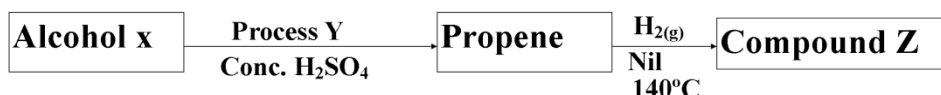

i) Draw the structure of alcohol X. (1mk)

ii) Name process Y. (1mk)

.....
.....

iii) Write the molecular formula of the 5th member in which propene belong. (1mk)

3. Silicon (IV) oxide has a structure similar to that of diamond. Part of the structure is shown below.

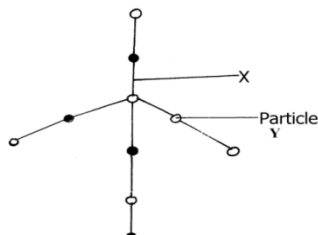

a) What does x represent? (1mk)

b) What type of structure is shown by the diagram? (1mk)

c) Predict one physical property of silicon (IV) oxide and explain how it is related to its structure. (1mk)

4. Describe how a dry solid sample of lead (II) chloride can be prepared using the following reagents dilute nitric (V) acid dilute hydrochloric acid and lead (II) carbonate. (3mks)

5 a) State Graham's law of diffusion. (1mk)

.....
.....

b) Ammonia gas diffuses 1.41 times faster than gas XH_3 . Determine the relative atomic mass of element X. (H = 1, N = 14) (2mks)

6. An ore of iron was found to contain 7g of iron and 3g. of oxygen. (Fe = 56 O = 16)

a) Workout its empirical formula. (2mks)

.....

b) Write a balanced equation for reaction of the oxide in (a) with hot carbon. (1mk)

7. Carbon (iv) Oxide can undergo the changes below.

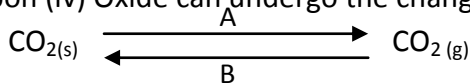

a) What are process A and B?

A (1mk)

B (1mk)

b) Suggest one use of carbon (iv) oxide that utilizes process A and B. (1 mk)

8. The table shows the PH values of solutions A to E

Solution	A	B	C	D	E
PH	6	13	2	10	7

a) What is meant by the term PH? (1mk)

b) Which of the solutions contains the largest number for hydroxide ions (1mk)

c) What will be the PH value of the mixture of D and E. (1mk)

9. The diagram below shows a Bunsen Burner when in use.

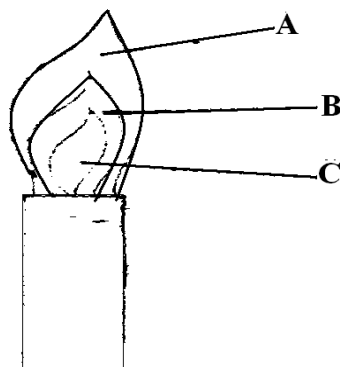

Which of the labeled parts is used for heating? Give a reason. (2mks)

10. The table below shows the atomic numbers of elements T, U, V and W. Study it and answer the questions that follow. The letters are not the actual symbols of the elements.

Element	T	U	V	W
---------	---	---	---	---

Atomic number	13	16	17	20
---------------	----	----	----	----

(a) What type of bond would be formed between:-

(i) elements U and W (1mk)

.....

(ii) elements V and U (1mk)

.....

(b) Which of the elements are metals. (1mk)

11. Oxygen gas can be prepared in the laboratory by catalytic decomposition of hydrogen peroxide.

(a) Write the chemical equation for the reaction. (1mk)

.....

(b) State the Name of the suitable catalyst used. (1mk)

.....

(c) Give one industrial use of oxygen (1mk)

.....

12. The diagram below shows electrolysis of lead bromide

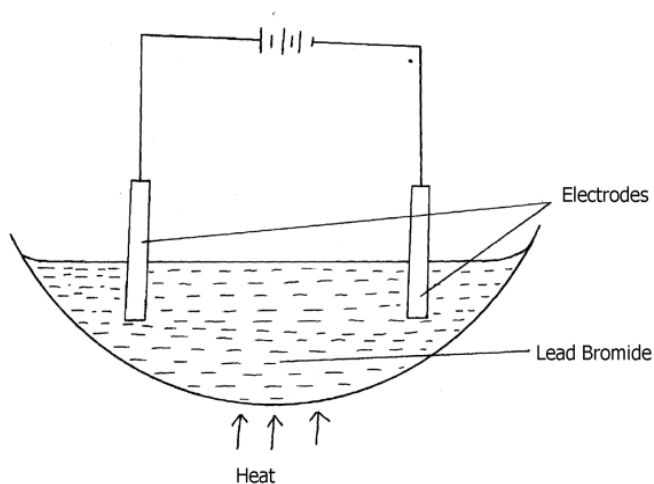

a) Label the anode. (1mk)

b) Write half equations to show reactions at cathode. (1mk)

c) State one application of electrolysis. (1mk)

..... 13. Below is a simplified scheme of solvay process. Study it and answer the questions that follow:

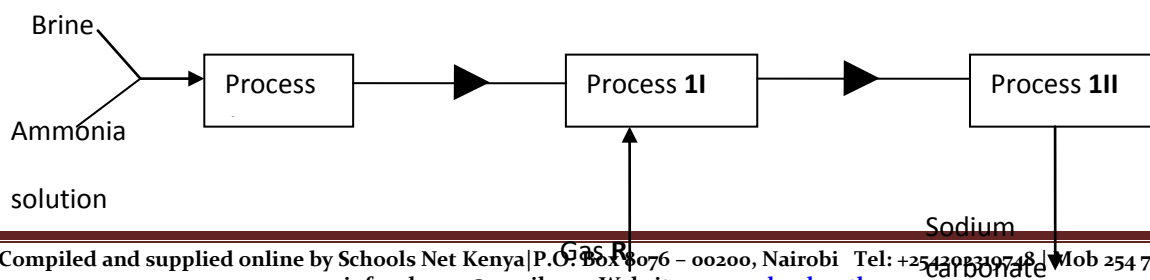

(a) Identify gas R..... (1mk)

(b) Write an equation for process III (1mk)

(c) Give one use of sodium carbonate (1mk)

14. The set-up below was used to investigate the properties of hydrogen

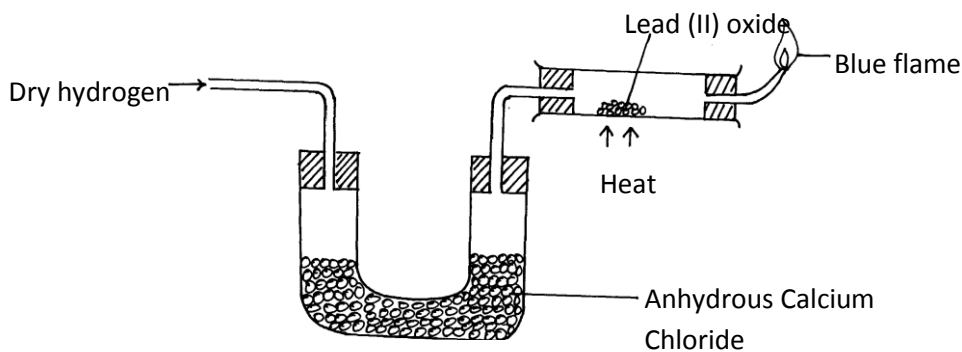

(i) State the observations that was made in the combustion tube as the reaction progressed to completion (2mks)

(ii) Write equations for the reactions ;

I) In the combustion tube (1mk)

II) At the jet of the delivery tube (1mk)

III) State the properties of hydrogen that were investigated (2mks)

15. Classify the process below as chemical or physical changes (2mks)

Process	Physical or chemical change
(a) Fractional distillation	
(b) Displacement reaction	
(c) Sublimation	
(d) Neutralization	

16. Iron reacts with oxygen in the presence of moisture to form hydrated iron (III) oxide. $Fe_2O_3 \cdot 2H_2O$

(a) What name is given to the process that produces hydrated iron (III) oxide ? (1 mk)

(b) What does the term 'hydrated' mean? (1 mk)

(c) Name one method used to prevent corrosion of iron. (1 mk)

17. The table **below** gives elements represented by letters which are not the actual symbols.

Element	U	V	W	X	Y	Z
Atomic No.	8	12	13	15	17	20

- (i) Select an element that can form divalent anion. (1 mark)
- (ii) What is the structure of the oxide of **W**? (1 mark)
- (iii) Compare the atomic radius of **W** and **X**. (1 mark)

18. Spots of three pure pigments A, B and mixture Z were placed on a filter paper and allowed to dry. The paper was then dipped in a solvent. The results obtained were as on the paper chromatogram.

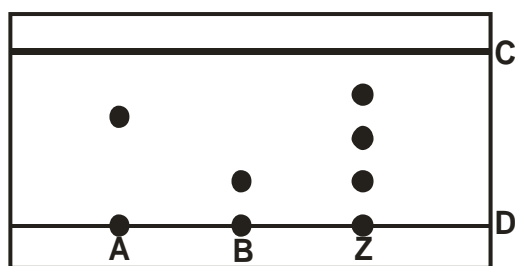

- i) Identify;
- a) Baseline. (1 mark)
- b) Solvent front. (1 mark)
- ii) Which pure pigment was component of Z.? (1 mark)

19. The following was used to investigate the effect of heat on a sample of Copper(II) Carbonate.

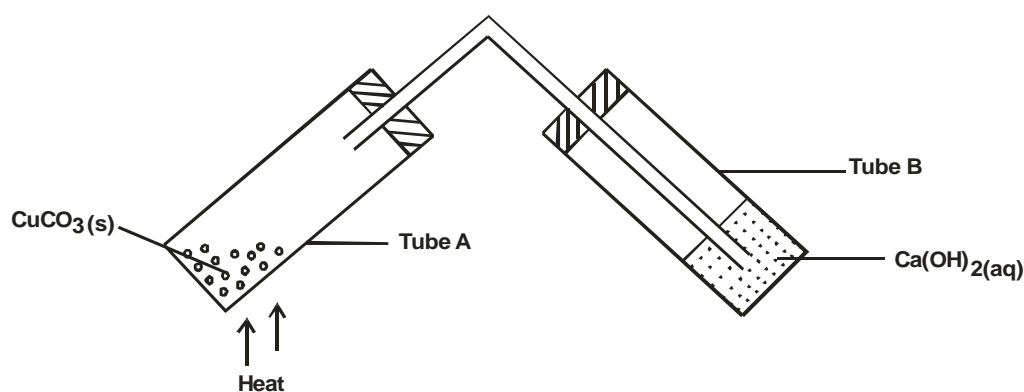

- a) State the observation made in test tube. (2 marks)
- A
- B.....
- b) Write equation for the reaction that occurs in tube A. (1 mark)

20. Sketch a graph of temperature time for a pure substance A with a melting point of 20⁰C and boiling point of 90⁰C and it is heated from 0⁰C to 100⁰C. (2marks)

21. The diagram below shows a burning “jiko” in a room which has sufficient supply of oxygen.

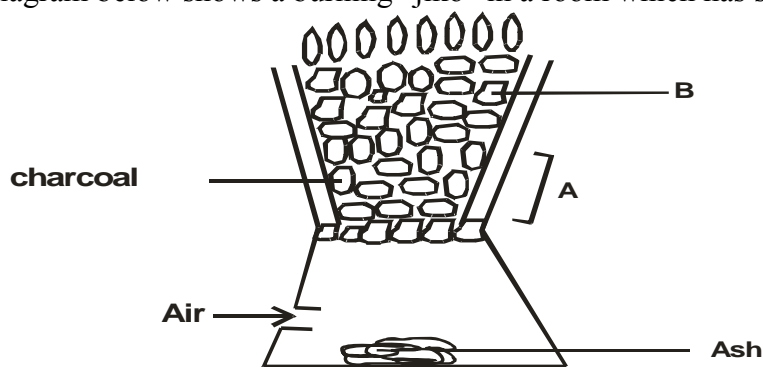

i) Using chemical equations, explain what happens at A and B. (2marks)

.....

ii) State the main danger of emitting excess carbon (IV) oxide into the atmosphere. (1mark)

.....

22. 3.22g of hydrated Sodium Sulphate, $\text{Na}_2\text{SO}_4 \cdot X \text{H}_2\text{O}$ were heated to a constant mass of 1.42g, determine the value of X in the formula. (Na = 23, S = 32, O = 16, H=1).

(2 mks)

23.a) The atomic number of Sulphur hydrogen and oxygen are 16, 1 and 8 respectively. Write the electron arrangement of Sulphur in the following substances.

(i) H_2S (1 mk)

(ii) SO_3^{2-} (1 mk)

(b) State the number of neutrons and electrons in the species of Aluminum shown below:

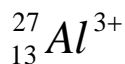

Neutrons (1mk)

Electrons (1 mk)

24. The graph below shows the behaviour of a fixed mass of a gas at constant temperature.

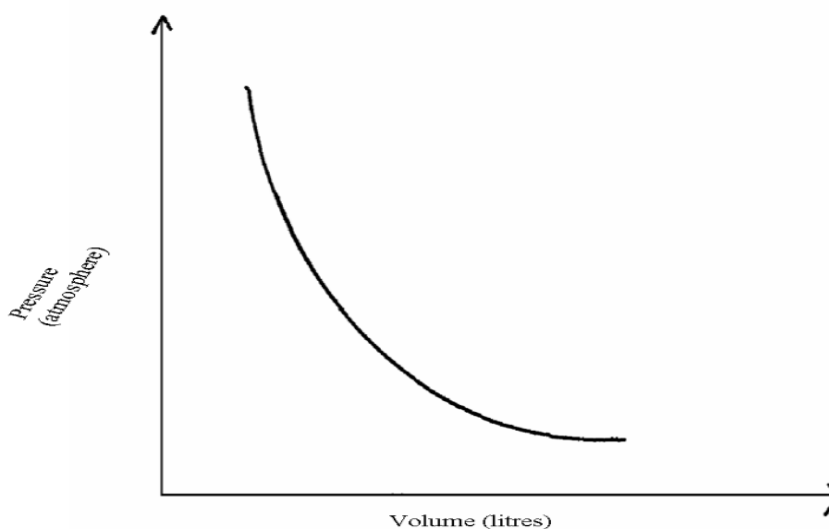

(i) What is the relationship between the volume and the pressure of the gas. (1 mk)

(ii) 12 litres of oxygen gas at one atmosphere pressure were compressed to 2.5 atmospheres pressure at constant temperature. Calculate the volume occupied by the oxygen gas. (2 mks)

25. Two samples of a similar substance from different containers were investigated. The graph below represents the variation of temperature with time when heated.

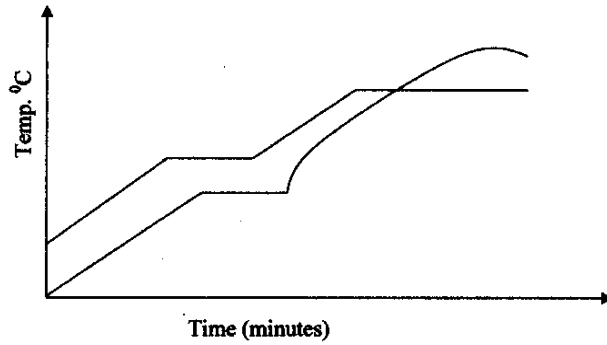

- a) Explain the variation in the curves of:
 Sample I.....(1mk)
 Sample II..... (1mk)
- b) Common salt is sprinkled on roads during winter in temperate countries. Explain. (1mk)

26. Study the diagram below and answer the questions.

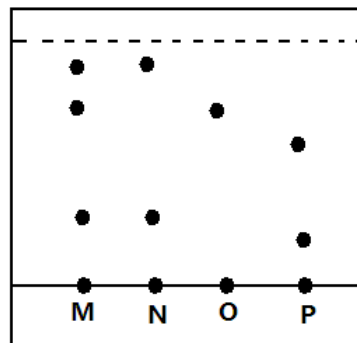

- a) On the diagram mark the base line. (1mk)
- b) Name the dyes which are in M. (1mk)
- c) Which mixture of dyes has the dye with lowest solubility? Explain. (1mk)

27. Study the diagram below and answer the questions that follow. The diagram shows the method used to separate components of mixture Q.

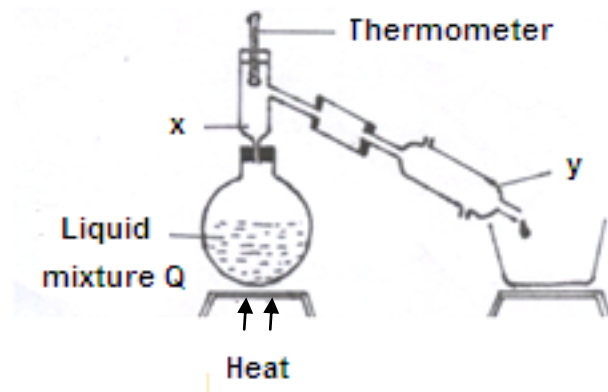

a) Name X and Y. (1mk)

X.....

Y.....

b) What is the purpose of apparatus X? (1mk)

c) Show the direction of flow of cold water used for cooling the vapour formed. (1mk)